

INSTALLATION INSTRUCTION Floor Mounted Bollards 3 Year Warranty

Product Code	6 Digit Code	Wattage	Lumens Output
ILBDA001-400	52-35-49	9W	420lm
ILBDA002-600	12-59-76	9W	420lm
ILBDA003-800	10-58-68	9W	420lm

Thank you for purchasing an INTEGRAL LED product. When installed correctly this unit will provide years of service. For support or warranty information please see integral-led.com.

Important Details – Please read prior to installation

1. Installation must be completed by a qualified electrician in accordance with all recognised local and national electrical and construction regulations.
2. Ensure that the power is OFF during installation and that power cannot be unexpectedly reconnected.
3. The light fitting is designed to operate with a 220-240V 50Hz/60Hz electricity supply.
4. Do NOT use the luminaire if damaged
5. This luminaire is rated at IP65, suitable for outdoor areas such as gardens, pathways, car parks. NOT suitable for water immersion.
6. Do not cover the light source.
7. Use the base plate as a template for marking the spacing for the anchor points, fix the base plate to a suitable, level fixing surface, ensuring the power supply cable is fed through the centre of the baseplate.
8. To avoid damage, DO NOT lift, carry or let the luminaire hang by any part of the wiring.
9. This product is Class I – Earth connection required.
10. Bollards are supplied pre-cabled, for electrical connection please use suitably rated connection boxes, similar to ILGDA008 or ILGDA009.
11. Failure to comply with the recommendations and instructions provided herein may cause damage to the luminaire or present a risk of injury or death (e.g. short circuit, fire, burns or electric shock).
12. Any modifications to the luminaire, incorrect installation or unfit positioning may be dangerous to users and may cause the warranty to become void.

Installation Instructions

13. Ensure that the power is OFF during installation and that power cannot be unexpectedly reconnected.
14. Follow the steps as laid out in the Figures. Diagrams are for illustrative purposes only.
15. Use suitable tools and fixings to mount the luminaire safely and securely to the fixing surface
16. Avoid any damage to any wiring. In the event of cable damage do not use the product.
17. When connecting the electrical supply please pay attention to the polarity. L=Live (Brown), N=Neutral (Blue), E=Earth (Green/Yellow). The luminaire is a CLASS I device – an EARTH connection is MANDATORY.

NEUTRAL = BLUE	LIVE = BROWN	GREEN/YELLOW = EARTH 
----------------	--------------	--

OUTDOOR

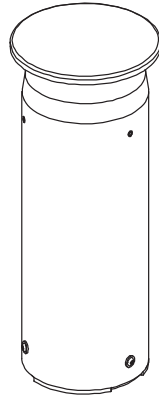

Floor Mounted Bollards

You will need

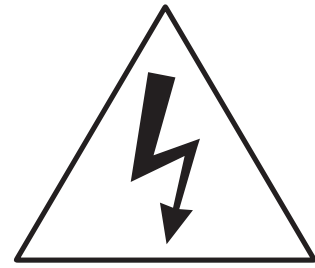
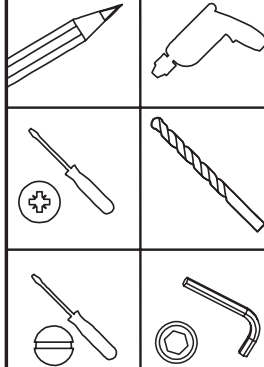

ON
OFF ✓

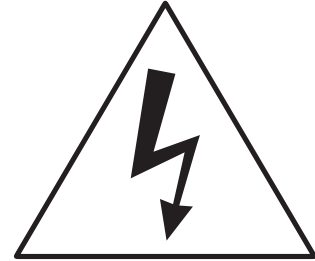
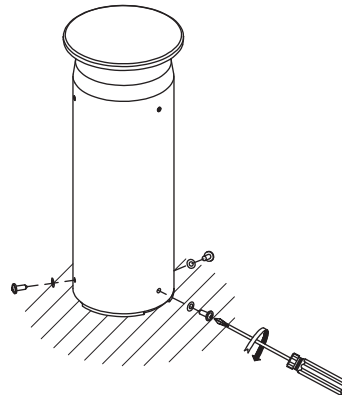
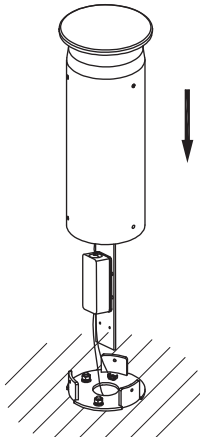
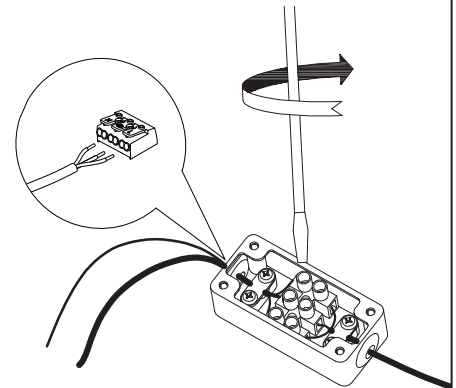
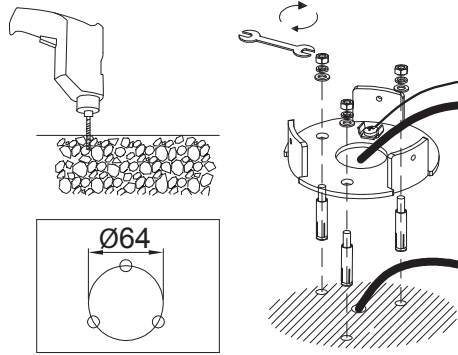
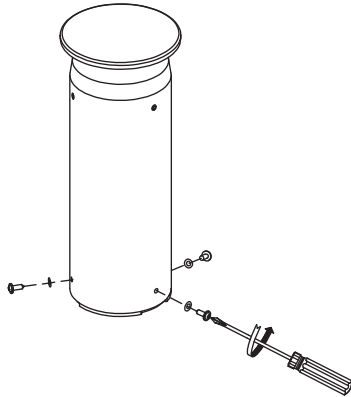

ON ✓
OFF



WASTE ELECTRICAL PRODUCTS SHOULD NOT BE DISPOSED OF WITH HOUSEHOLD WASTE. PLEASE RECYCLE WHERE FACILITIES EXIST. CHECK WITH YOUR LOCAL AUTHORITY FOR RECYCLING ADVICE.

CE **RoHS**
IP65



Non-Dimmable

Warranty/Technical and contact information are all available at www.integral-led.com

Integral LED is a division of Integral Memory plc:
Unit 6, Iron Bridge Close, Iron Bridge Business Park,
London, NW10 0UF, UK